

TUTTE LE OPERAZIONI DEVONO ESSERE EFFETTUATE DA PERSONALE SPECIALIZZATO
 ALL OPERATIONS MUST BE CARRIED OUT BY QUALIFIED PERSON - TOUS LES OPERATIONS DOIVENT ETRE EFFECTUEES PAR DES PROFESSIONELLES

1.
 Fix the bracket to the ceiling
 (use appropriate anchors
 depending on the type of wall).

 Fissare la staffa al soffitto
 (utilizzare tasselli appropriati
 in relazione al tipo di soffitto).

3.
 Fix the canopy to the bracket
 with the screws provided
 and adjust the grade
 and height of the lamp
 using the steel cables.

 Fissare il rosone alla staffa
 con le viti fornite
 e regolare l'inclinazione
 e l'altezza della lampada
 usando i cavi d'acciaio.

5.
 Insert the diffuser from
 the bottom of the shade.

 Inserire il diffusore
 dalla parte inferiore
 del paralume.

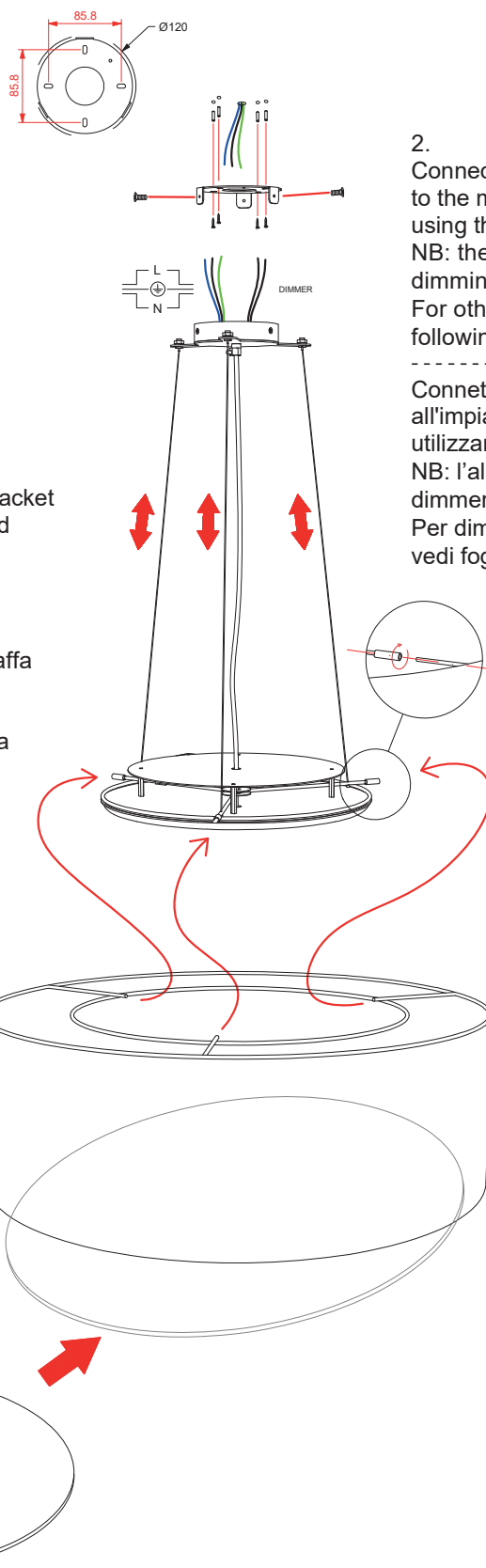

2.
 Connect the lamp
 to the main power
 using the connectors provided.
 NB: the driver is set up for PUSH
 dimming system, as a standard.
 For other dimming systems, see
 following page.

 Connettere la lampada
 all'impianto elettrico
 utilizzando i connettori
 forniti.
 NB: l'alimentatore è predisposto per
 dimmerazione PUSH, come standard.
 Per dimmerazione con altro sistema,
 vedi foglio seguente.

4.
 Align the shade pivots
 with the central cross
 and unscrew the nuts.

 Allineare i perni del telaio
 con la croce centrale
 e svitare i dadi.

MAXI JOLLY HC DALI 60



Direct current dimmable electronic drivers with DIP-SWITCH
Alimentatori elettronici regolabili in corrente continua con DIP-SWITCH

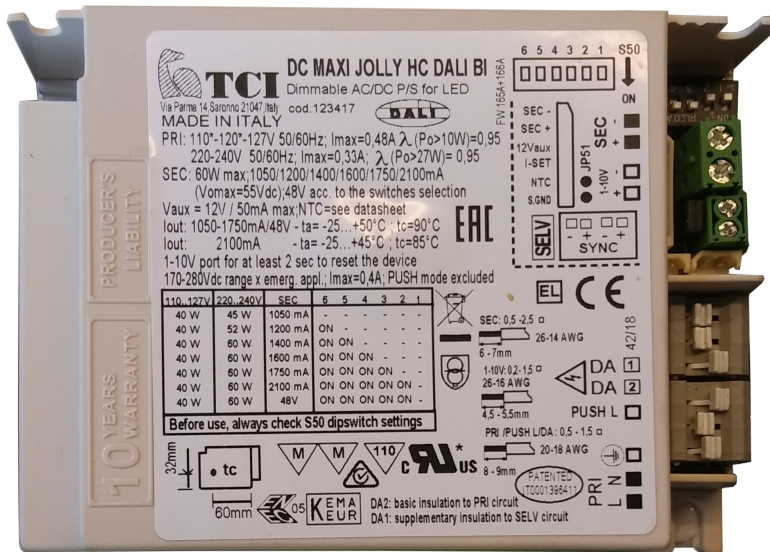
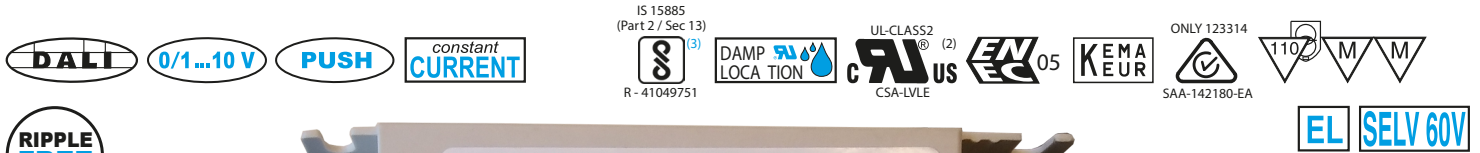

IP 20 SCREW FIXING Ø90 3,54" Weight - Peso gr. 245 / 8,6 oz. Pcs - Pezzi 35 BUILT-IN SCREW FIXING Weight - Peso gr. 225 / 7,9 oz. Pcs - Pezzi 40

Compatible with ZHAGA (AM2)

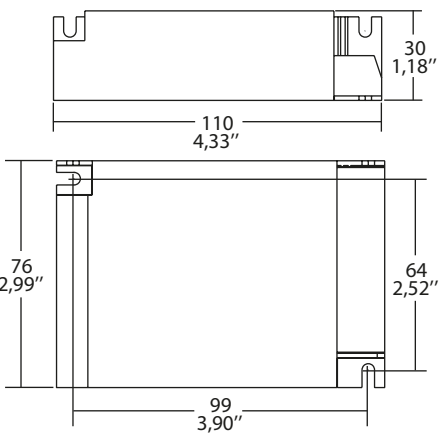

Wiring diagram - Schema di collegamento (Max. LED distance on page info8 - Massima distanza LED a pagina info8)

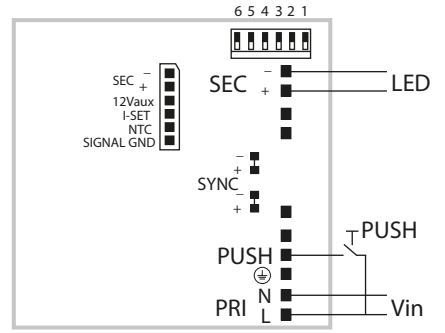

PUSH diagram - Collegamento PUSH

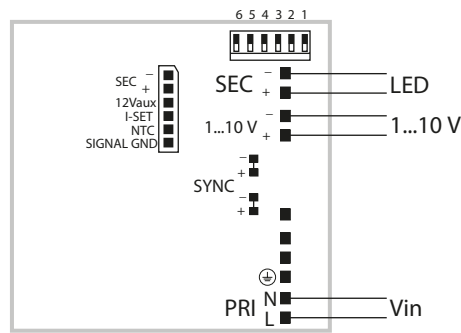

1...10 V diagram - Collegamento 1...10 V

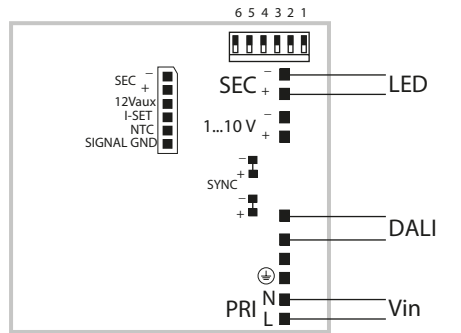

DALI diagram - Collegamento DALI